

Geschwindigkeiten • Speeds • Vitesses

FU 4-125/4		$v = 0 \rightarrow 80 \text{ m / min.}$	4.0 kW	400 V 50 Hz 3 Ph
SR 10-155/3		$v = 0 \rightarrow 25 \text{ m / min.}$	2 x 10.0 kW	
K WB 80/4		$v = 0 \rightarrow 0.75 \text{ min}^{-1}$	2 x 80 Nm	
HK max. = 215 m 6 - Lagen / 6 - layers / 6 - couches				
Type FU 45-63/5 45.0 kW	 [t] vs [m/min]		Motorenleistung ges. Total motor output Puissance moteur (ohne/without/sans SR 10-155/3) ~ 65 kW	Anschlussleistung Connected power Puissance installée 80 kVA
	 [t] vs [m/min]			
HK max. = 215 m 6 - Lagen / 6 - layers / 6 - couches				
Type SR WB 66-63/4F 66.0 kW			$\rightarrow 112 \text{ m / min}$ 2 500 kg	Motorenleistung ges. Total motor output Puissance moteur (ohne/without/sans SR 10-155/3) ~ 80 kW
			$\rightarrow 70 \text{ m / min}$ 4 200 kg	
			$\rightarrow 45 \text{ m / min}$ 6 300 kg	
			$\rightarrow 28 \text{ m / min}$ 12 500 kg	
			$\rightarrow 56 \text{ m / min}$ 5 000 kg $\rightarrow 35 \text{ m / min}$ 8 400 kg $\rightarrow 23 \text{ m / min}$ $\rightarrow 14 \text{ m / min}$	
Anschlussleistung Connected power Puissance installée 160 kVA				

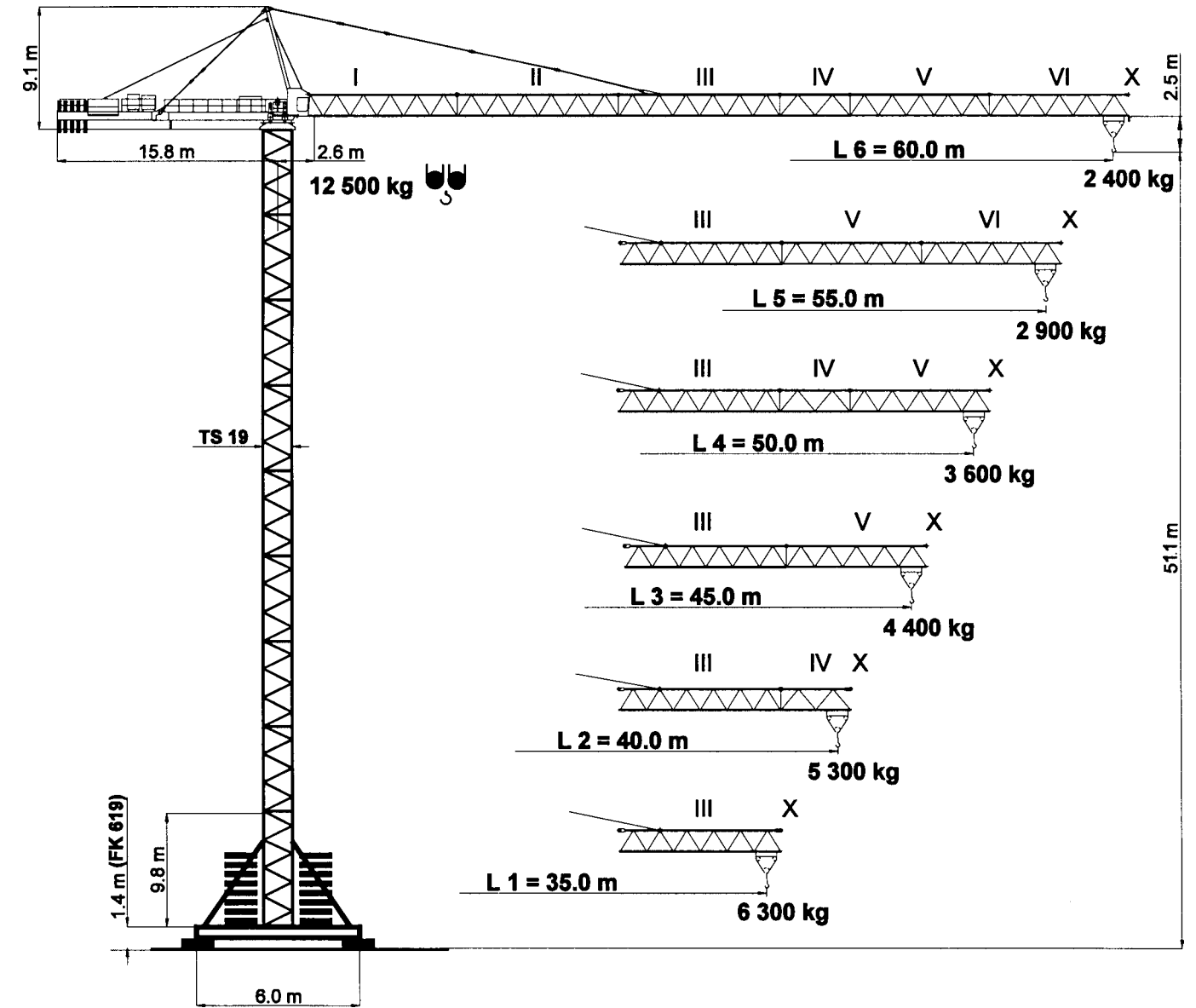

Unsere Vertretung:
Our representative:
Notre représentant:

PROSCHWITZ
BAUMASCHINEN



TEREX PEINER GmbH

Gottbillstraße 1-7 · D-54294 Trier
 Telefon: ++49 (6 51) 81 00 8 - 0
 Telefax: ++49 (6 51) 8 93 00 u. 8 76 40
 internet: <http://www.terex-peiner.de>
 e-mail: info@terex-peiner.de



simple, available and cost effective™

FEM
1001/3 A3
Max. Tragfähigkeit
Lifting capacity
Force de levage



Turmversionen • Tower versions • Versions de tours

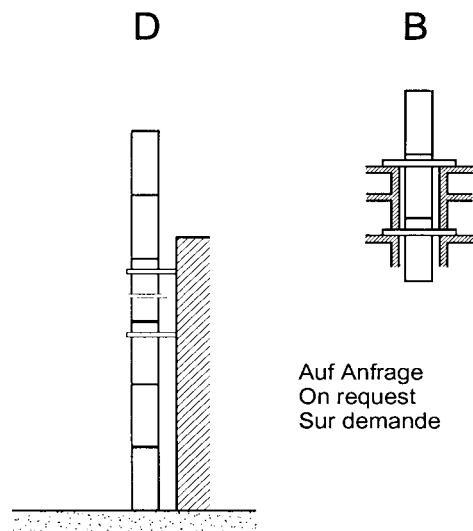
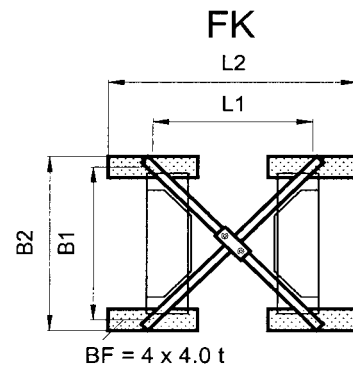
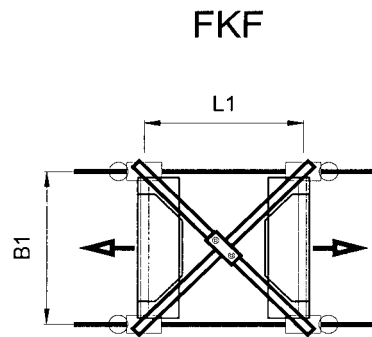
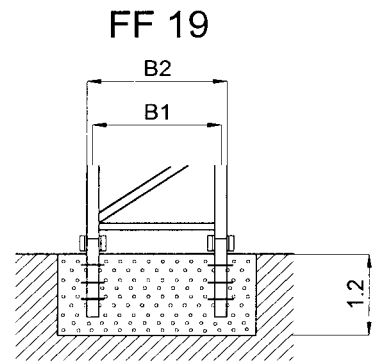
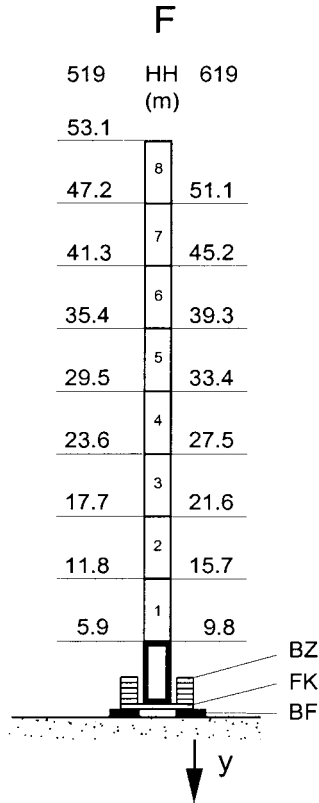
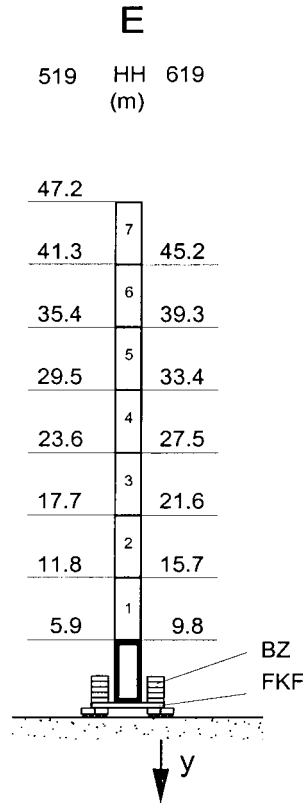
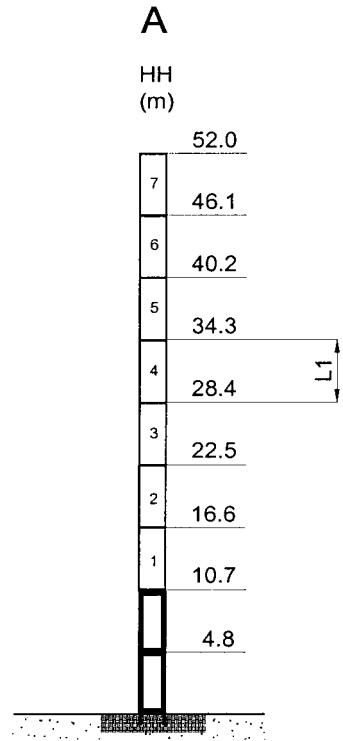

Auf Anfrage
On request
Sur demande

	B1	B2	L1	L2	y / ●	y / ■
	m				kN	
FK 519	5.00	6.05	5.05	7.85	836	905
FK 619	6.00	7.00	6.00	8.80	674	710
FKF 519	5.05		5.05		808	743
FKF 619	6.00		6.00		661	592
TS 19.1	1.90	2.06	5.9			
TS 19.2	1.90	2.06	11.8			
TSV 19.1	1.90	2.06	5.9			
TSV 19	1.90	2.06	9.8			

● in Betrieb / in operation / en service
■ außer Betrieb / out of operation / sans service

Ausladung und Tragfähigkeit • Radius and capacity • Portée et charge

Ausleger Jib Flèche	Max. Tragfähigkeit Max. Capacity Charge max.	Ausladung (m) und Tragfähigkeit (t) Radius (m) and capacity (t) Portée (m) et charge (t)																
		max. 12.5 / 6.3 t																
m	12.5 t	18	20	22	26	28	30	32	35	38	40	43	45	48	50	53	55	60
L5 60.0	2.6 - 15.3 m	11.84	9.17	8.22	6.77	6.21	5.72	5.30	4.76	4.31	4.04	3.70	3.49	3.22	3.05	2.83	2.70	2.40
L5 55.0	2.6 - 16.1 m	12.50	9.75	8.74	7.21	6.61	6.10	5.65	5.08	4.60	4.33	3.96	3.74	3.45	3.28	3.04	2.90	
L4 50.0	2.6 - 17.2 m	12.50	10.54	9.46	7.82	7.18	6.63	6.15	5.54	5.03	4.73	4.33	4.10	3.79	3.60			
L3 45.0	2.6 - 18.3 m	12.50	11.28	10.12	8.37	7.69	7.10	6.59	5.93	5.39	5.07	4.65	4.40					
L2 40.0	2.6 - 18.9 m	12.50	11.75	10.55	8.73	8.02	7.41	6.88	6.20	5.63	5.30							
L1 35.0	2.6 - 19.1 m	12.50	11.93	10.71	8.86	8.15	7.53	6.99	6.30									

Ballastierung • Ballast • Lest

Version F – mit Zentralballast und Fundamentballast / with Central ballast block and Foundation block / avec Lest de base et Bloc de fondation – BZ + BF

HH (m)	5.9	11.8	17.7	23.6	29.5	35.4	41.3	47.2	53.1
FK 519 (t)	58.2	58.2	58.2	58.2	68.2	68.2	78.2	98.2	118.2
HH (m)	9.8	15.7	21.6	27.5	33.4	39.3	45.2	51.1	
FK 619 (t)	48.2	48.2	48.2	48.2	48.2	58.2	68.2	78.2	

Version E – mit Zentralballast / with Central ballast block / avec Lest de base – BZ

HH (m)	5.9	11.8	17.7	23.6	29.5	35.4	41.3	47.2
FKF 519 (t)	52.2	62.2	62.2	62.2	72.2	72.2	82.2	92.2
HH (m)	9.8	15.7	21.6	27.5	33.4	39.3	45.2	
FKF 619 (t)	42.2	42.2	42.2	42.2	52.2	52.2	62.2	

Gegengewichtsballast • Counterweight • Contrepoids

Ausleger / Jib / Flèche	L1	L2	L3	L4	L5	L6
	10.45	12.45	13.60	14.60	15.60	16.60
BG (t)	2 x 3.15		3 x 3.15	2 x 3.15	1 x 3.15	
	1 x 4.15	3 x 4.15	1 x 4.15	2 x 4.15	3 x 4.15	4 x 4.15